

# 9-Line 3-5 Volt Low Capacitance SCSI Active Terminator

## FEATURES

- Complies with SCSI, SCSI-2 and SCSI-3 Standards
- 2.7V to 7V Operation
- 1.8pF Channel Capacitance during Disconnect
- 0.5µA Supply Current in Disconnect Mode
- 110 Ohm/2.5k Programmable Termination
- Completely Meets SCSI Hot Plugging
- -400mA Sourcing Current for Termination
- +400mA Sinking Current for Active Negation Drivers
- Trimmed Termination Current to 4%
- Trimmed Impedance to 7%
- Current Limit and Thermal Shutdown Protection

## DESCRIPTION

The UCC5614 provides 9 lines of active termination for a SCSI (Small Computer Systems Interface) parallel bus. The SCSI standard recommends active termination at both ends of the cable.

The UCC5614 is ideal for high performance 3.3V SCSI systems. The key features contributing to such low operating voltage are the 0.1V drop out regulator and the 2.7V reference. The reduced reference voltage was necessary to accommodate the lower termination current dictated in the SCSI-3 specification. During disconnect the supply current is typically only 0.5µA, which makes the IC attractive for battery powered systems.

The UCC5614 is designed with an ultra low channel capacitance of 1.8pF, which eliminates effects on signal integrity from disconnected terminators at interim points on the bus.

The UCC5614 can be programmed for either a 110 ohm or 2.5k ohm termination. The 110 ohm termination is used for standard SCSI bus lengths and the 2.5k ohm termination is typically used in short bus applications. When driving the TTL compatible DISCNCT pin directly, the 110 ohm termination is connected when the DISCNCT pin is driven low, and disconnected when driven high. When the DISCNCT pin is driven through an impedance between 80k and 150k, the 2.5k ohm termination is connected when the DISCNCT pin is driven low, and disconnected when driven high.

**continued**

## BLOCK DIAGRAM

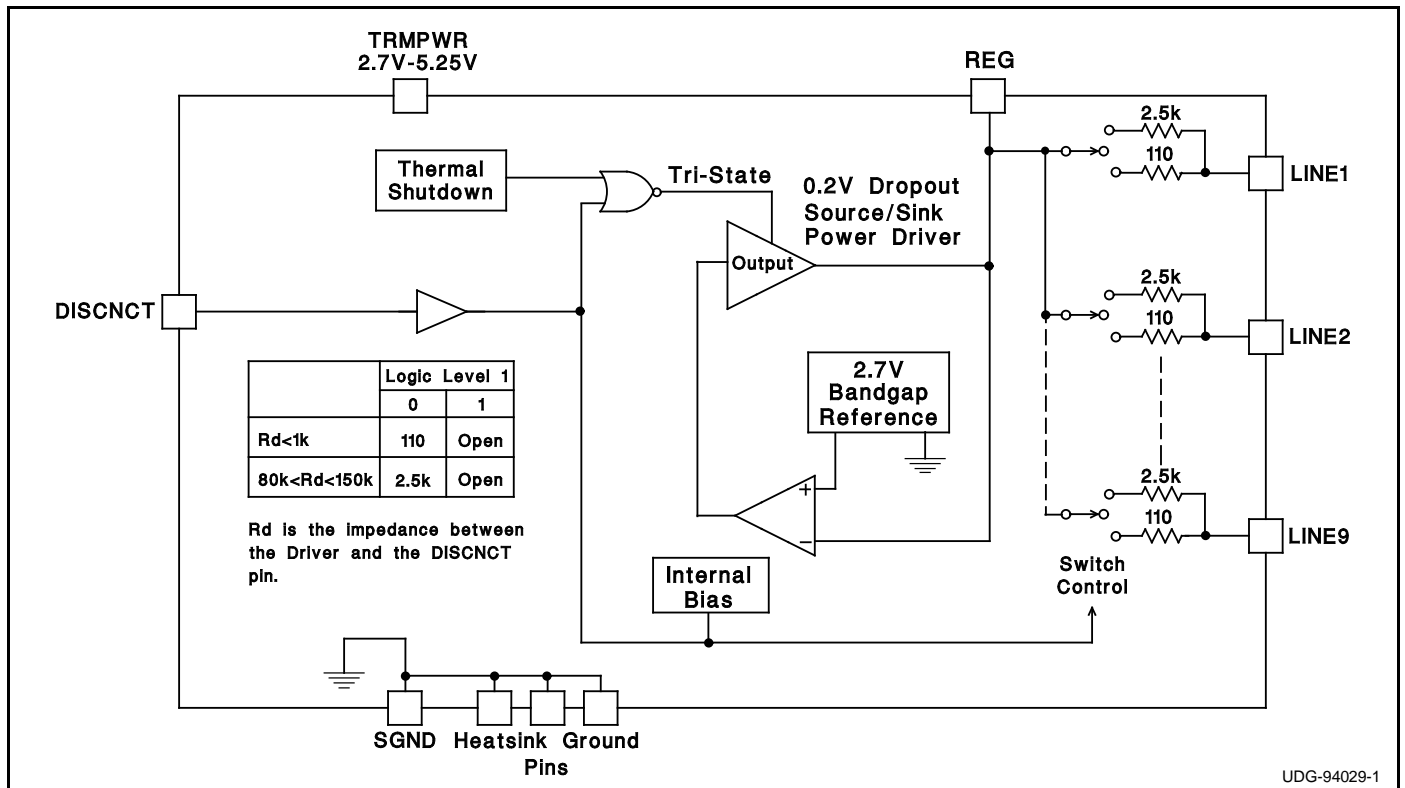

Circuit Design Patented

**Description Continued**

The power amplifier output stage allows the UCC5614 to source full termination current and sink active negation current when all termination lines are actively negated.

The UCC5614 is pin for pin compatible with Unitrode's other 9 line SCSI terminators, allowing lower capacitance and lower voltage upgrades to existing systems. The UCC5614, as with all Unitrode terminators, is completely hot pluggable and appears as high impedance at the terminating channels with  $V_{TRMPWR} = 0V$  or open.

Internal circuit trimming is utilized, first to trim the 110 ohm termination impedance to a 7% tolerance, and then

most importantly, to trim the output current to a 4% tolerance, as close to the max SCSI-3 spec as possible, which maximizes noise margin in fast SCSI operation.

Other features include thermal shutdown and current limit.

This device is offered in low thermal resistance versions of the industry standard 16 pin narrow body SOIC, 16 pin ZIP (Zig-Zag In Line package), 24 pin TSSOP and 28 pin PLCC.

**ABSOLUTE MAXIMUM RATINGS**

Tempwr Voltage	..... +7V
Signal Line Voltage	..... 0V to +7V
Regulator Output Current	..... 0.6A
Storage Temperature	..... -65°C to +150°C
Operating Temperature	..... -55°C to +150°C
Lead Temperature (Soldering, 10 Sec.)	..... +300°C

*Unless otherwise specified all voltages are with respect to Ground. Currents are positive into, negative out of the specified terminal.*

*Consult Packaging Section of Unitrode Integrated Circuits databook for thermal limitations and considerations of packages.*

**RECOMMENDED OPERATING CONDITIONS**

Tempwr Voltage	..... 2.7V to 5.25V
Signal Line Voltage	..... 0V to +5V
Disconnect Input Voltage	..... 0V to Tempwr

**CONNECTION DIAGRAMS**

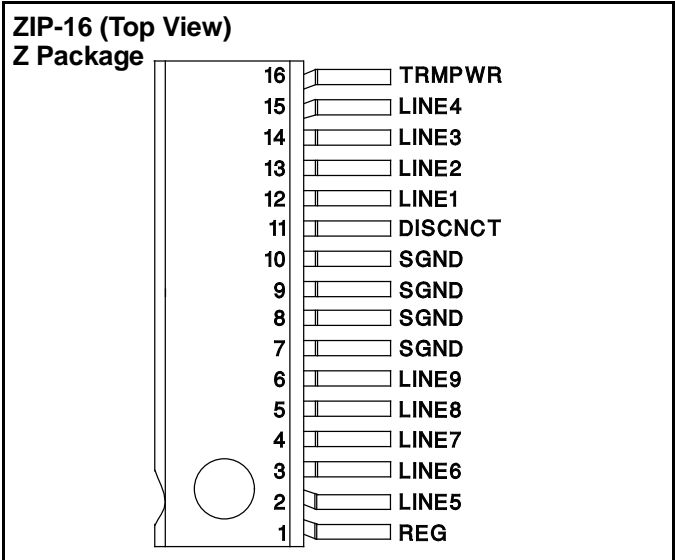
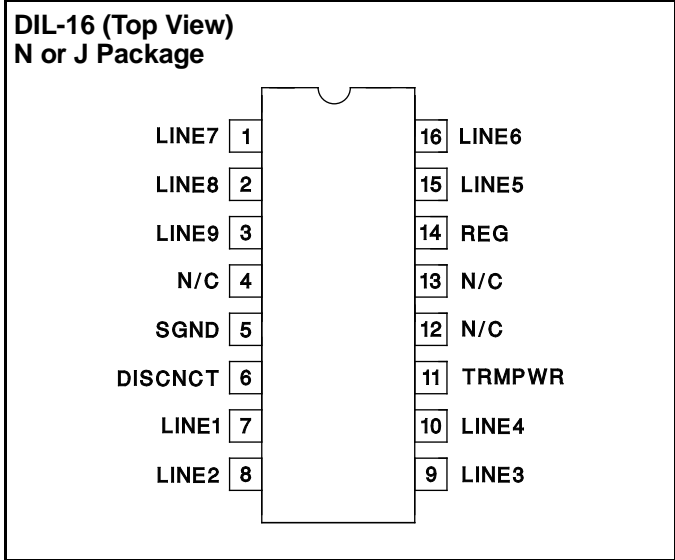

*Note: Drawings are not to scale.*

**CONNECTION DIAGRAMS (cont.)**

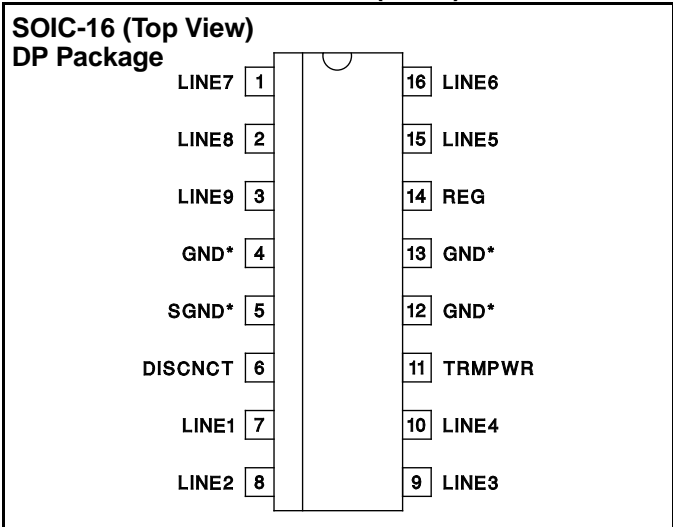

\* DP package pin 5 serves as signal ground; pins 4, 12, 13 serve as heatsink/ground.

Note: Drawings are not to scale.

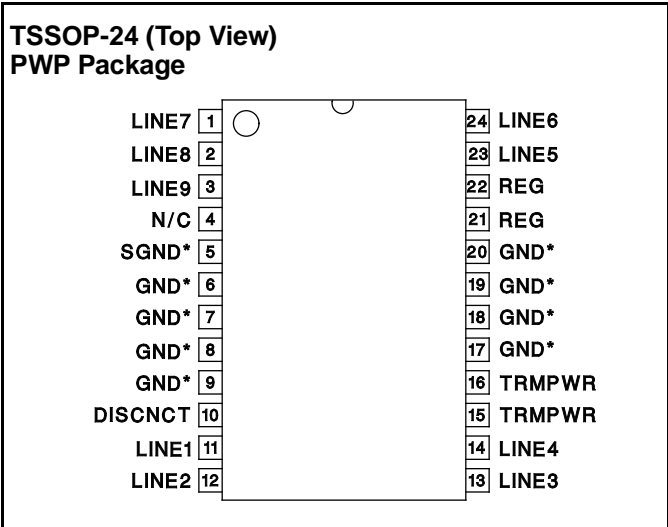

\* PWP package pin 5 serves as signal ground; pins 6, 7, 8, 9, 17, 18, 19, and 20 serve as heatsink/ground.

**ELECTRICAL CHARACTERISTICS** Unless otherwise stated, these specifications apply for  $T_A = 0^\circ\text{C}$  to  $70^\circ\text{C}$ .  
 $\text{TRMPWR} = 3.3\text{V}$ ,  $\text{DISCNCT} = 0\text{V}$ ,  $R_{\text{DISCNCT}} = 0\text{ ohms}$ .  $T_A = T_J$ .

PARAMETER	TEST CONDITIONS	MIN	TYP	MAX	UNITS
<b>Supply Current Section</b>					
Termpwr Supply Current	All termination lines = Open		1	2	mA
	All termination lines = 0.2V		210	218	mA
Power Down Mode	DISCNCT = Termpwr		0.5	5	$\mu\text{A}$
<b>Output Section (110 ohms - Terminator Lines)</b>					
Terminator Impedance		102.3	110	117.7	Ohms
Output High Voltage	(Note 1)	2.5	2.7	3.0	V
Max Output Current	$V_{\text{LINE}} = 0.2\text{V}$ $T_J = 25^\circ\text{C}$	-22.1	-23	-24	mA
	$V_{\text{LINE}} = 0.2\text{V}$	-21	-23	-24	mA
	$V_{\text{LINE}} = 0.2\text{V}$ , $\text{TRMPWR} = 3\text{V}$ $T_J = 25^\circ\text{C}$ (Note 1)	-20.2	-23	-24	mA
	$V_{\text{LINE}} = 0.2\text{V}$ , $\text{TRMPWR} = 3\text{V}$ (Note 1)	-19	-23	-24	mA
	$V_{\text{LINE}} = 0.5\text{V}$			-22.4	mA
Output Leakage	DISCNCT = 2.4V, TRMPWR = 0V to 5.25V		10	400	nA
Output Capacitance	DISCNCT = 2.4V (Note 2) (DP Package)		1.8	2.5	pF
<b>Output Section (2.5k ohms - Terminator Lines) (<math>R_{\text{DISCNCT}} = 80\text{k ohms}</math>)</b>					
Terminator Impedance		2	2.5	3	k $\Omega$
Output High Voltage	TRMPWR = 3V (Note 1)	2.5	2.7	3.0	V
Max Output Current	$V_{\text{LINE}} = 0.2\text{V}$	-0.7	-1	-1.4	mA
	$V_{\text{LINE}} = 0.2\text{V}$ , $\text{TRMPWR} = 3\text{V}$ (Note 1)	-0.6	-1	-1.5	mA
Output Leakage	DISCNCT = 2.4V, TRMPWR = 0 to 5.25V		10	400	nA
Output Capacitance	DISCNCT = 2.4V (Note 2) (DP Package)		1.8	2.5	pF
<b>Regulator Section</b>					
Regulator Output Voltage	$5.25\text{V} > \text{TRMPWR} > 3\text{V}$	2.5	2.7	3.0	V
Drop Out Voltage	All Termination Lines = 0.2V		0.1	0.2	V
Short Circuit Current	$V_{\text{REG}} = 0\text{V}$	-200	-400	-800	mA

**ELECTRICAL CHARACTERISTICS (cont.)** Unless otherwise stated, these specifications apply for  $T_A = 0^\circ\text{C}$  to  $70^\circ\text{C}$ .  
 $\text{TRMPWR} = 3.3\text{V}$ ,  $\text{DISCNCT} = 0\text{V}$ ,  $\text{RDISCNCT} = 0$  ohms.  $T_A = T_J$ .

PARAMETER	TEST CONDITIONS	MIN	TYP	MAX	UNITS
<b>Regulator Section (cont.)</b>					
Sinking Current Capability	$V_{\text{REG}} = 3\text{V}$	200	400	800	mA
Thermal Shutdown	(Note 2)		170		$^\circ\text{C}$
Thermal Shutdown Hysteresis	(Note 2)		10		$^\circ\text{C}$
<b>Disconnect Section</b>					
Disconnect Threshold	$\text{RDISCNCT} = 0$ & $80\text{k}$	0.8	1.5	2.0	V
Input Current	$\text{DISCNCT} = 0\text{V}$		30	50	$\mu\text{A}$

Note 1: Measuring each termination line while other 8 are low (0.2V).  
 Note 2: Guaranteed by design. Not 100% tested in production.

**APPLICATION INFORMATION**

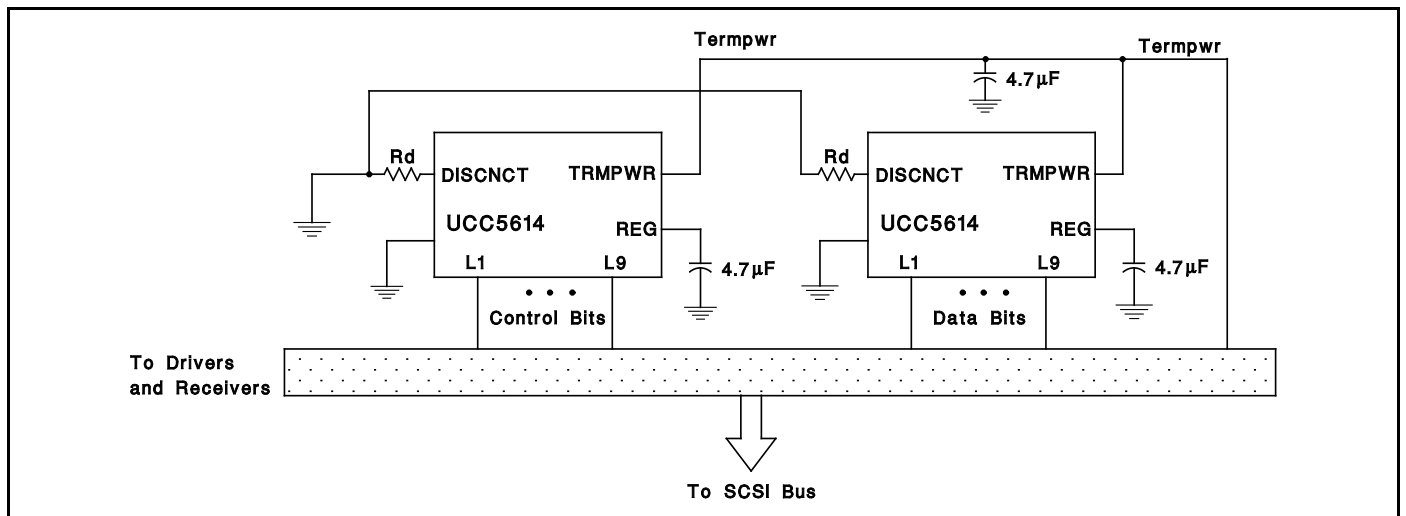

Figure 1: Typical SCSI Bus Configurations Utilizing 2 UCC5614 Devices

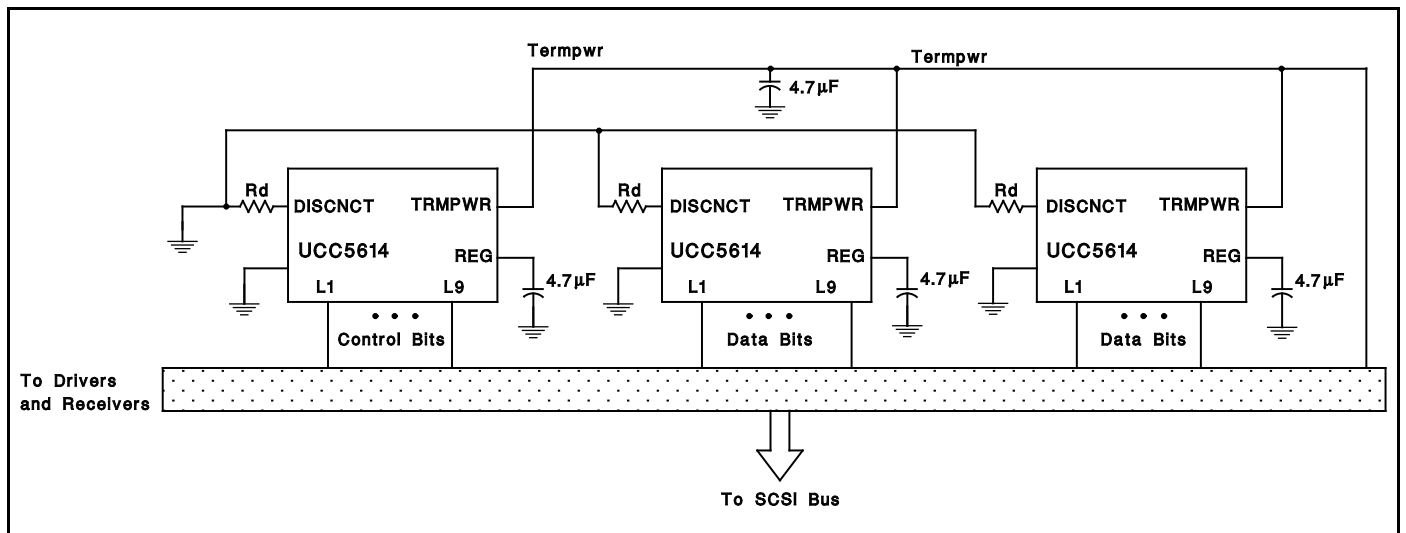

Figure 2: Typical Wide SCSI Bus Configurations Utilizing 3 UCC5614 Devices.